



imageMill

Cintel International Ltd.
Watton Road
WARE
Hertfordshire
SG12 0AE
England
Tel: +44 (0) 1920 463939
Fax: +44 (0) 1920 460803
Email: sales@cintel.co.uk



User Guide Issue 3.0

GRACE STEADY GRACE_SR

While every effort has been made to ensure that the contents of this document are accurate, Cintel International equipment is under constant review to bring about improvements in design and a unit may differ in detail from that described.

© Cintel International Ltd 2008

The copyright of this document is the property of Cintel International Ltd. and the document contains proprietary information of Cintel International Ltd. It is supplied in confidence and must not be used for any purpose other than that for which it is supplied. No part of the document shall be reproduced, published or disclosed to a third party without the prior written consent of Cintel International Ltd

Contents

Introduction

General Description of imageMill.....	3
General Description of imageMill applications... ..	3
Safety Warnings and Information.....	3

Installation and Configuration

imageMill connections to equipment.....	5
Power Sequencing.....	7
imageMill Local Operation.....	8
imageMill Configuration Hierarchy.....	9
imageMill GUI installation.....	10
Setting imageMill Delay.....	12
Connecting to a network.....	12
Connecting to an OEM controller.....	12

Operation

GRACE Operating Procedure.....	13
GRACE GUI.....	14
Using GRACE.....	15
Using GRACE_SR.....	16
Additional GRACE information.....	17
STEADY Operating Procedure.....	18
STEADY GUI	19
Using STEADY.....	20

Specification

imageMill.....	22
----------------	----

Software and License Management

Software Update... ..	24
License Renewal... ..	24
Software/Firmware License... ..	25

Introduction

General Description of imageMill

imageMill is a hardware platform that provides high speed image data processing. imageMill is multi-standard capable – Standard Definition, High Definition and Data (HSDL).

Designed to be operated from a remote location, i.e. remote controller/programmer, imageMill can also be controlled from the Local Control Panel. In addition a Graphical User Interface (GUI) is supplied that can be run on just about any PC platform running Microsoft Windows.

General Description of available imageMill applications (all are options)

GRACE is a Film Grain and Video Noise management application. GRACE incorporates powerful real time Spatial correction with simple to use controls. GRACE is available in SD, HD and Data option.

GRACE_SR is an option for GRACE users which provides additional Recursive correction. GRACE_SR is available in SD, HD and Data options.

STEADY is a High Quality Image Stabiliser. STEADY is capable of sub-pixel Video and Data stabilisation using superior sinx/x interpolation. STEADY can stabilise any images whether sourced from film or video. STEADY is available in SD, HD and Data options.

imageMill additionally has the option to output HD from Data (HSDL) for Monitoring purposes.

Safety Warnings and additional Information

CE Declaration of Conformity

This equipment has been tested and found to comply with standards BS EN55103-1, BS EN55022, BS EN61000-3-2, BS EN61000-3-3, BS EN55103-2, BS EN61000-6-2, BS EN61000-4-2, BS EN61000-4-3, BS EN61000-4-4, BS EN61000-4-5, BS EN61000-4-6, BS EN61000-4-11.

Test Report Number ETS/J922/EN.

FCC Part 15 Class A Declaration of Conformity

This equipment has been tested and found to comply with the limits for a Class A digital device pursuant to part 15J of the FCC rules. These limits are designed to provide reasonable protection against harmful interference when the equipment is operated in a commercial environment. This equipment generates, uses, and can radiate radio frequency energy and, if not installed and used in accordance with the instruction manual, may cause harmful interference to radio communications.

Waste from Electrical and Electronic Equipment (WEEE)

This equipment is designed to comply with EN 50419

Compliance TBC

Restriction of Hazardous Substances (RoHS)

This equipment is designed to comply with directive 2002/95/EC

Compliance TBC



Warning

Electrical supplies in excess of 50 (fifty) volts are potentially hazardous or lethal; supplies of up to 264V exist within imageMill. IMAGEMILL MUST ONLY BE OPERATED WITH ALL COVERS IN PLACE; covers may only be removed by qualified service personnel for maintenance purposes.

1) Protection against Electrostatic Discharge

Electrostatic discharge (ESD) can degrade or destroy electronic devices during shipping, handling, installation and general operational procedures. Such devices and the items, of which they are component parts, are referred to as ESD-sensitive parts. A majority of ESD failures can be attributed to a charge delivered to an ESD-sensitive part by a human being, very often a small level of charge such as is accumulated in normal circumstances can cause damage. Cintel International Ltd has implemented procedures to protect electronic devices during the manufacture, assembly, test, shipment and installation of its products.

2) Environmental

Relative Humidity: High humidity environments permit static charges to dissipate more effectively, for example- a person walking across a carpeted floor accumulates up to 10 times greater electrostatic voltage at 40% relative humidity than at 70-90% and up to 30 times greater on a vinyl floor. This does not mean that high humidity is safe as the level of charge can still exceed the susceptibility of many devices.

3) Work surfaces

Surfaces covered with common vinyl plastics are the most common source of static electricity and should be avoided. A discharge path, which will ground both the surface and personnel handling ESD-sensitive parts, should be used.

4) Information for Users on Disposal of Old Equipment



Attention This symbol is only valid in the European Union

[European Union]

This symbol indicates that the electrical and electronic equipment should not be disposed of as general household waste at its end-of-life. Instead, the product should be handed over to the appliance collection point for the recycling of electrical and electronic equipment for proper treatment, recovery and recycling in accordance with your national legislation.

By disposing of this product correctly, you will help to conserve natural resources and will help prevent potential negative effects on the environment and human health which could otherwise be caused by inappropriate waste handling of this product. For more information about collection point and recycling of this product, please contact your local municipal office, your household waste disposal service or Cintel International, or your agent of Cintel International.

Penalties may be applicable for incorrect disposal of this waste, in accordance with national legislation.

(Business Users)

If you wish to dispose of this product, please contact service@cintel.co.uk to obtain information about returning the product.

[Other Countries outside the European Union]

If you wish to dispose of this product, please do so in accordance with applicable national legislation or other rules in your country for the treatment of old electrical and electronic equipment.

Installation

imageMill connections to equipment

imageMill accommodates both 4444 and 422 SD/HD Digital serial channels. Two sets of dual link I/Os are included.

For 422 operation connect only to A1 and A2 I/Os. For 4444 operation connect the dual links to A1,B1 and A2,B2 I/Os. In all modes additional 422 monitoring output (or HD from HSDL if the option is fitted) is available for both channels at C1 and C2. ImageMill does not require external gen lock as it derives all signals from the 4444 or 422 inputs.

Interface to a remote PC for remote GUI control is via Ethernet. Note that if a regular Ethernet cable is used for this link a crossover coupler or crossed cable will be required. Remote control from an OEM will be via RS422 – port 1.

The ac power connector is a standard IEC connector. The power fuse is of 3 Amp rating. Adjacent to the power cable is the Power Switch; please note that the power should not be removed from imageMill without reference to the Front Panel display shutdown instructions

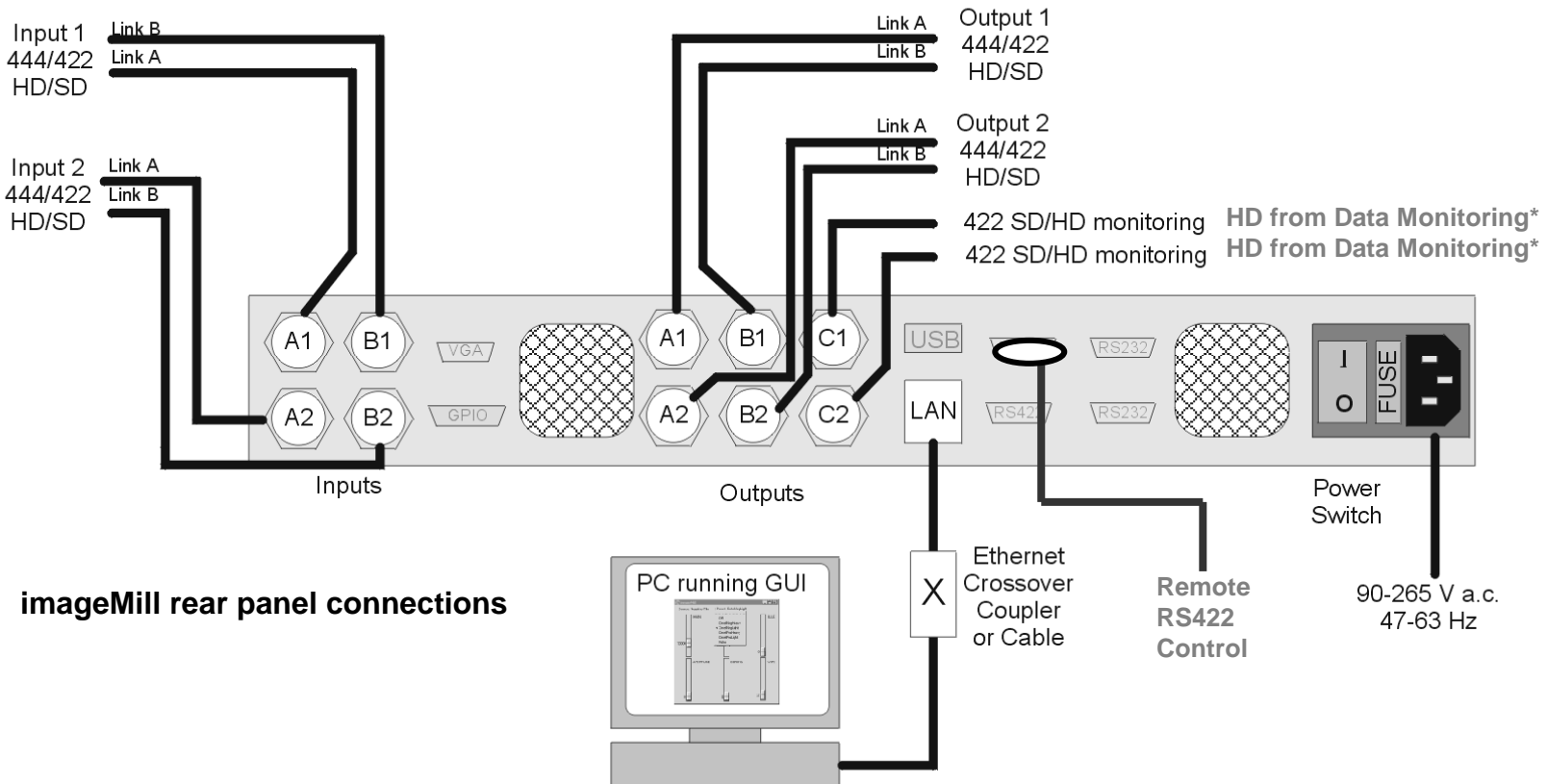

*requires HSDL Monitoring Option

Multi-standard imageMill GRACE and STEADY

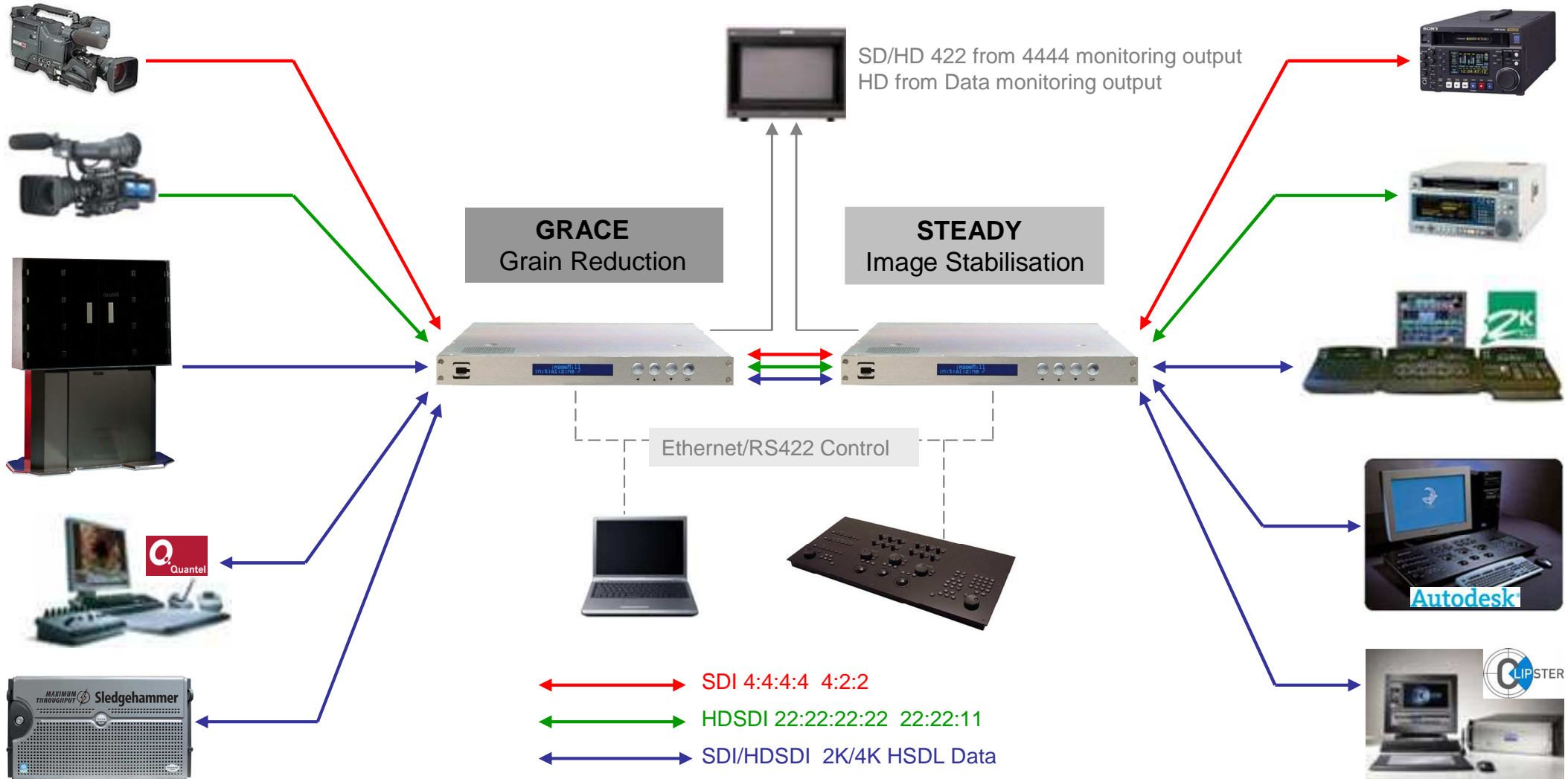

Power Sequencing

To power up imageMill, apply appropriate AC power to the rear connector.
 Operate the on/off switch adjacent to the AC connector
 imageMill will proceed to power up automatically, firstly displaying an initialising message, then a software/firmware message.
 When imageMill has completed power up the front panel will display the **imageMill** menu.
 You may then choose to select the appropriate imageMill application, **GRACE** or **STEADY**.
 You may also select to **Configure** imageMill or **Shut-down**
 Do NOT shutdown by removing power or operating the power switch, except in an emergency.
 To shutdown select **Shutdown** and **Yes Please** from the menu, then wait 15 seconds before switching off or removing power from ImageMill.

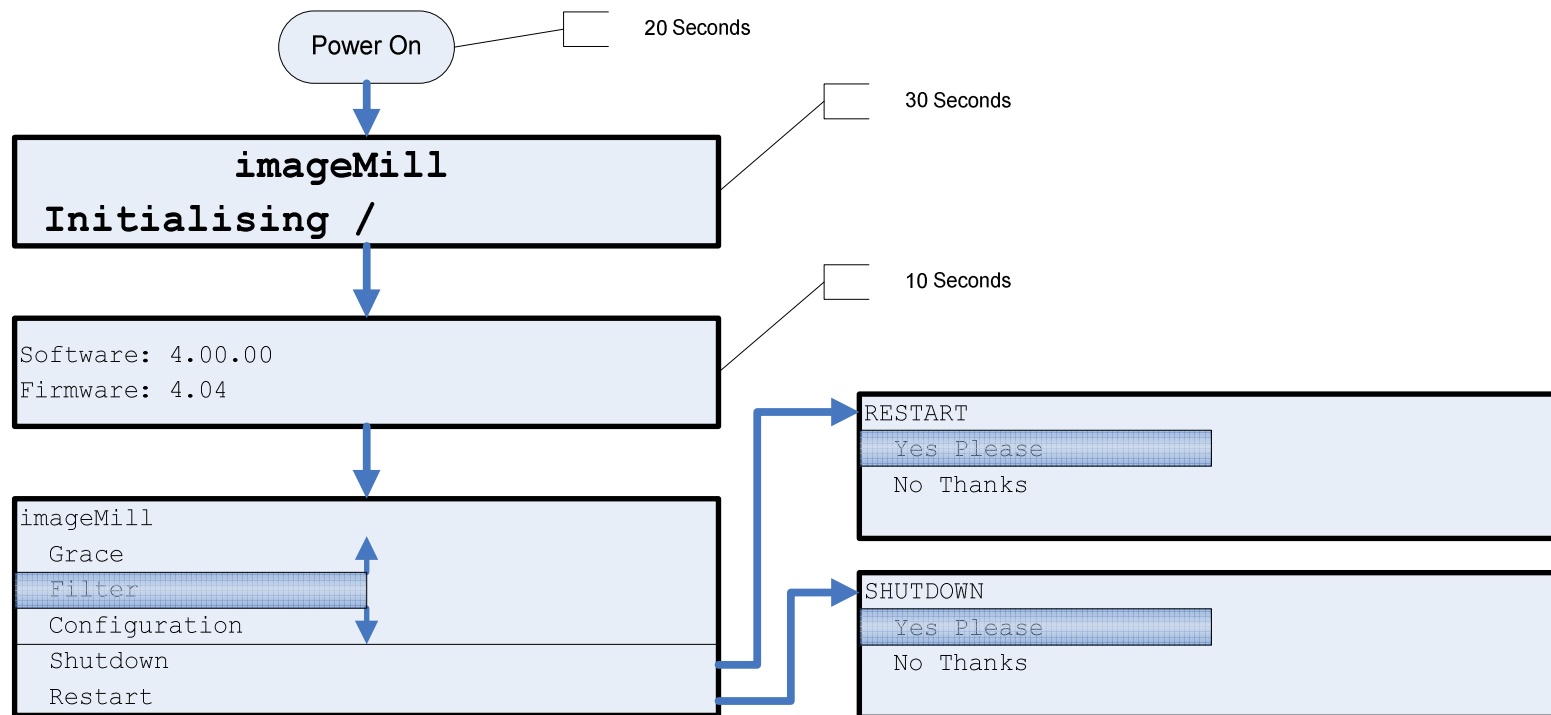

imageMill Operation

GENERAL

Although designed to be operated from a remote control desk imageMill can also be controlled and configured from Control Panel and via a GUI operating from a suitable PC .This section makes reference to local controls. The function of these controls will be similar to those available from a remote desk.

Local Control Panel

The imageMill front panel includes a menu display for parameter selection and a set of four buttons to enable control of any of the selected parameters. The buttons, from left to right, control display selection as follows:

“Back”

“Up”

“ Down”

“OK”



imageMill Front Panel

The Menu Display comprises a Top line containing the Mode of control; the subsequent three lines offer selection within the mode of control. If more selections are available a Down Arrow to the right of the display will indicate that scrolling down will display more selections. Once scrolled down an additional Up arrow will indicate there are other selections available.

The highlighted item will be selected if the **OK** button is pressed. The asterix shows the item currently selected.

In the example shown above, User control parameters are displayed, The previous selection made in this user area was **HF**, and the current user has scrolled to **Main**. Depression of the **OK** button will call up the User, Main adjustment; subsequent return to this user menu will show the asterisk against the **Main** selection.

The **Back** button will back up through the menu Mode of control

imageMill Configuration

The following Menu Hierarchy applies to all imageMill operations, regardless of which application is fitted.

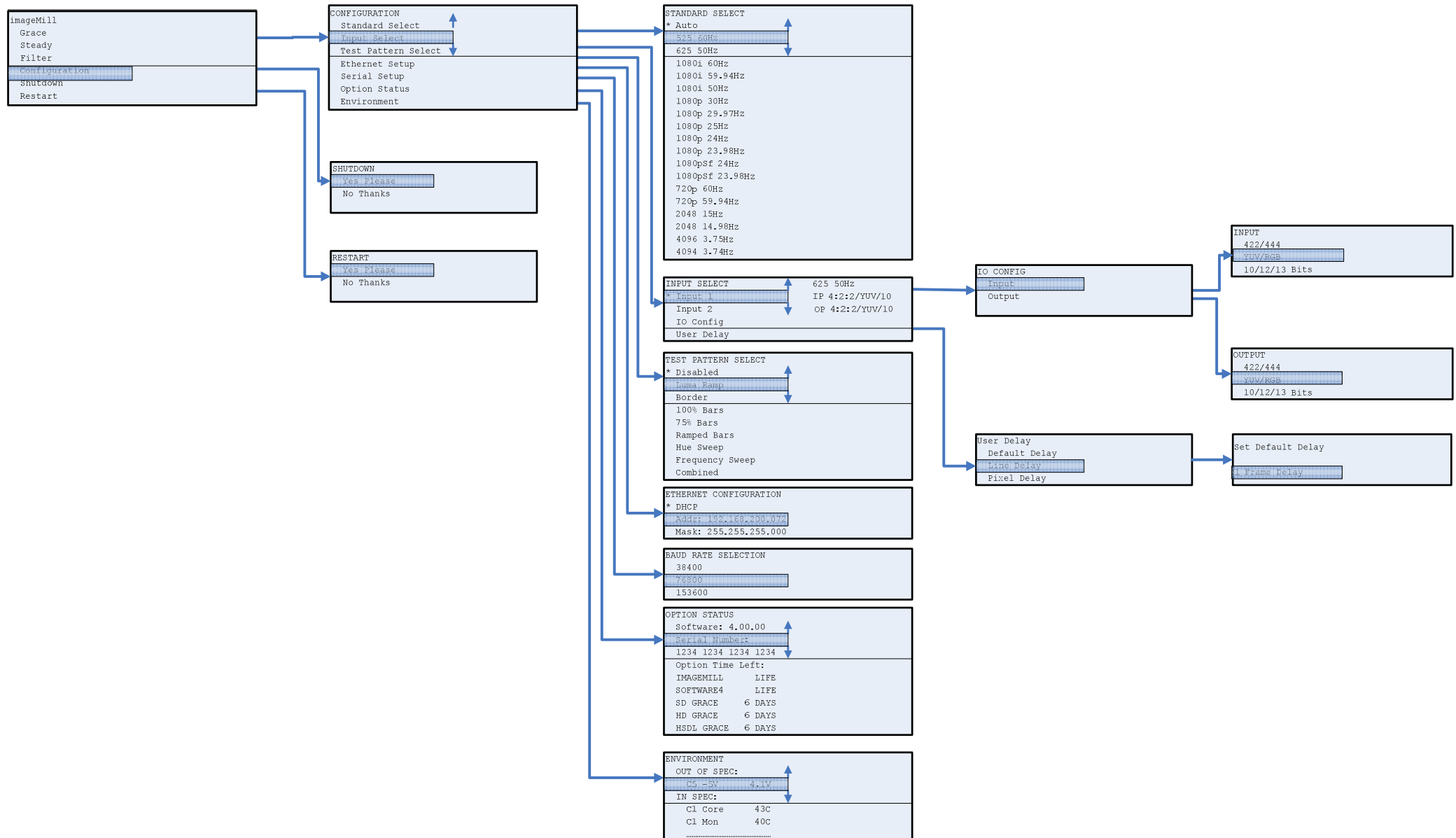

GUI installation

Setting the imageMill to work stand alone with the GUI from a PC

From the imageMill front panel, select **ethernet setup** via the configuration menu, this will enable you set your subnet mask and IP address. The factory default IP is set to 192.168.200.72 and the subnet mask is set to 255.255.255.0

PC setup (Note: PC processor speed needs to be 500Mhz minimum)

When not networked you need to turn DHCP off (Dynamic Host Configuration Protocol), when in this mode a DHCP server would automatically allocate a unique IP address to the PC.

From the PC control panel select >> network connections >> local area connection icon >> under the general tab select properties >> internet protocol (TCP/IP) >> tick use the following IP address, enter a unique address, 192.168.200.70 would be good for the default IP address above (subnet mask 255.255.255.0)

If connecting directly between the PC and imageMill (not via a hub or switcher) you will need to use an Ethernet crossover cable.

Installing the GUI on your PC

Copy the imagemill.exe file from the CD into a folder on your local drive (this enables a targets.dat file to be created) and setup a shortcut to your desktop. Open the GUI and select the setup tab, this will show a panel similar to this:

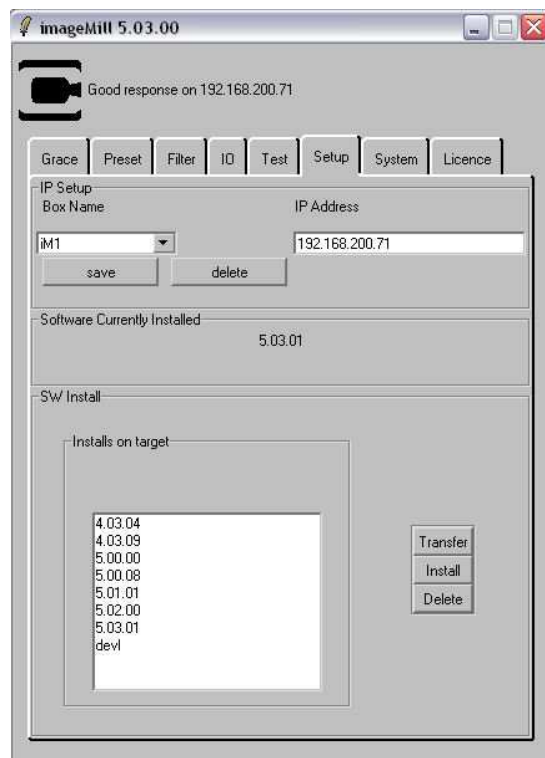

Depending on version, the IP address displayed may be 1.1.1.1, if so, then in this example enter the value shown and press **save** (you may wish to name the imageMill box at this stage, to do this type over the text in the box name field and save) this will then associate this IP address with the name given.

The panel should now display the text “Good response on 192.168.200.72”. If not try closing down the GUI and re-opening it. If the GUI is still not displaying the message, then you can try and ping the box from the command prompt (type ping *ipaddress*)

If this fails and assuming that the cable is of the correct type and that the correct addresses have been entered into the imageMill, PC and GUI, it could indicate that the software is not running correctly. From the box select **Restart** from the top level menu, then re-open the GUI.

Note:

It is important NOT to enter leading zero's on the PC GUI i.e. DO NOT type 192.168.200.072

Graphical User Interface

These pages on the GUI are common for both **GRACE** and **STEADY**.

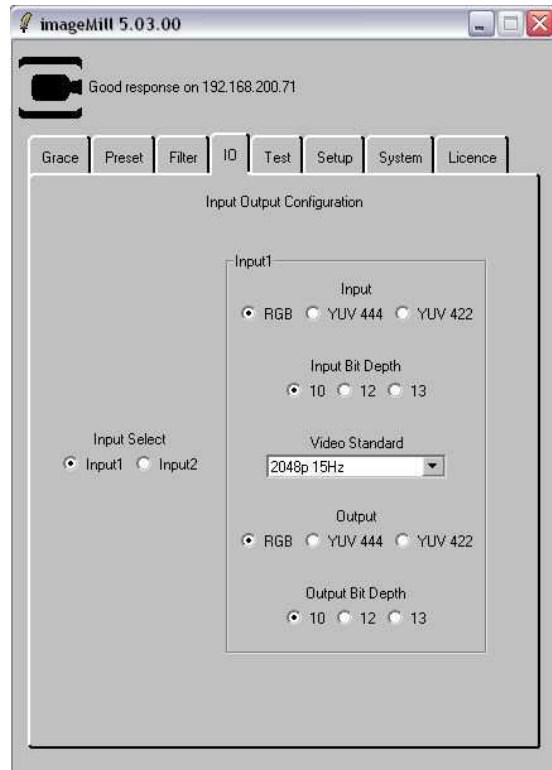

1) Input and Output Configuration

Sets Video/Data Standard*, colour space and bit depth.

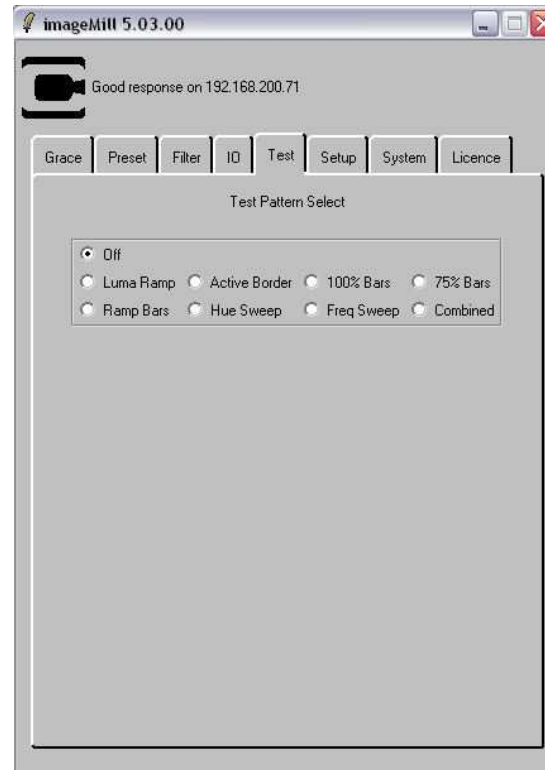

2) Test pattern Selection

Selects Output test patterns.

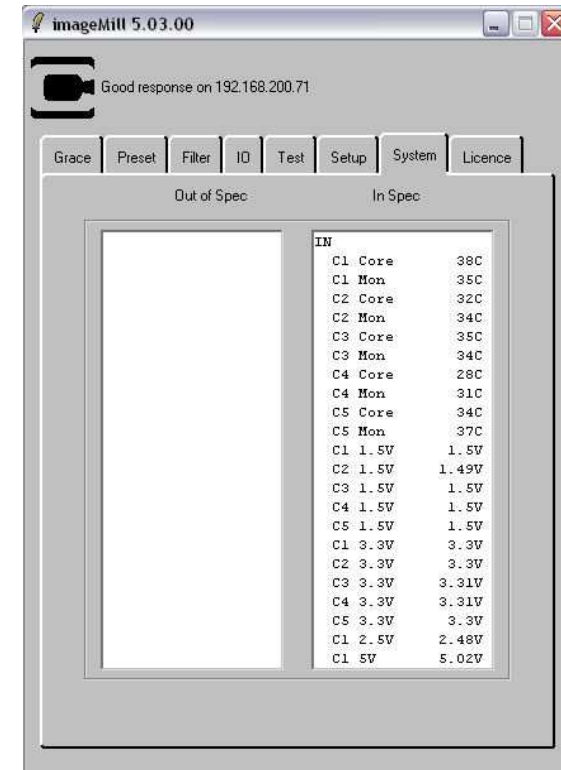

3) System Environment Monitoring

Monitors internal Temperatures and Voltages, the 'out of spec' window should be blank.

*dependent upon which options - SD, HD or Data - are fitted

Setting imageMill delay

This can be adjusted from the imageMill front panel by selecting **user delay** via **configuration** and **input select**. The imageMill is set to a default of 1 frame. The range of delay will depend upon the video standard being used. The minimum delay is 14 lines for GRACE and 18 lines for STEADY. Maximum delay is up to 10 frames in SD and 3 frames in HD.

Connecting to a network

From the imageMill front panel, select **ethernet setup** via the **configuration** menu, this will enable you set the subnet mask and IP address to suit your network.

You can however select **DHCP** from this menu, therefore allowing the network to allocate an address automatically.

See section above [Installing the GUI on your PC](#), and enter the IP address in the setup panel of the GUI to either the manual setting given on the imageMill box or the address automatically allocated.

Note: If **DHCP** is used and the box is subsequently powered down, it will probably be allocated a different address the next time it is switched on, the GUI setup panel must be changed to reflect this.

If adding further boxes to a network, setup as before, and on the GUI setup panel, enter a new box name and the appropriate IP address and **save**.

Firewalls: If there are problems getting imageMill to work through firewalls you may need to open up two ports in the firewall. These are:

21	ftp port for software and license updates
3490	for main control

If in any doubt contact your company Network or IT Supervisor

Connecting to an OEM controller

Connect an RS422 cable to RS422 (1) on the imageMill and to either:-

Pandora Pogle	=> "Noise Reducer"	or
daVinci 2K	=> available skt.	or
Tangent Synergy	=> available skt.	

When both an OEM controller and the GUI are attached, both will have control (which ever sends the command last has control) the GUI will always reflect the status.

Note: An OEM software update may be required. Contact the appropriate manufacturer accordingly.

Baud Rate should be set dependent upon which remote controller is used. This is set in Local Panel > Configuration > Serial Set up

daVinci	76800
Pandora	38400

GRACE Operating Procedure

GRACE is the real time noise reduction option for imageMill. GRACE can be controlled by the supplied GUI application running on any PC connected to the imageMill box by Ethernet. Refer to the installation rear panel drawings for connection details. See GRACE GUI description on page 14 of this Handbook.

Once imageMill has been configured for suitable I/O signals, a number of general controls are available to the User.

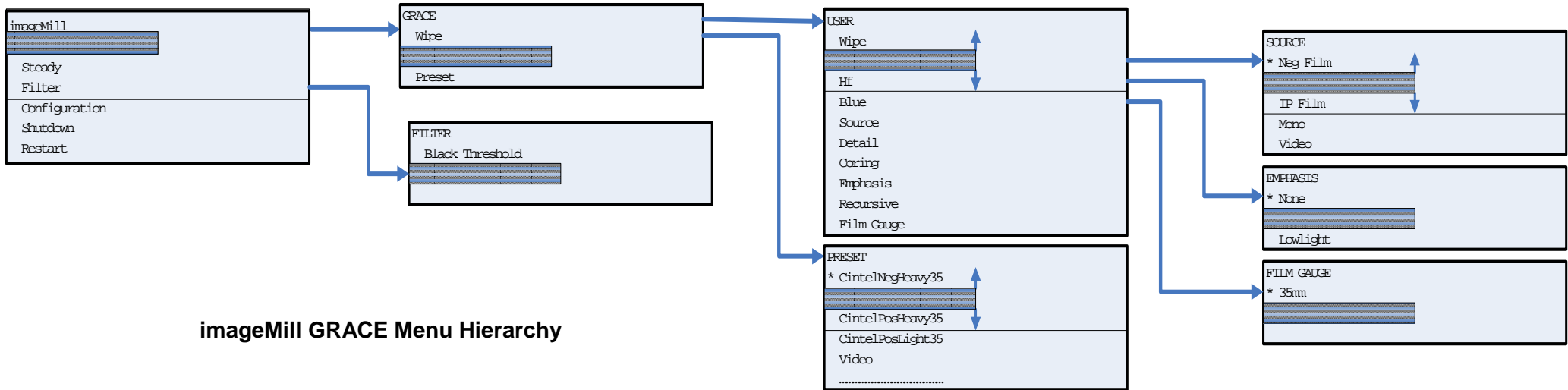

GRACE GUI

GRACE is supplied with a Graphical User Interface (GUI) to provide control of all user parameters (See installation section on page 10 for details). Similar controls will be available on a Remote Programmer/Controller device.

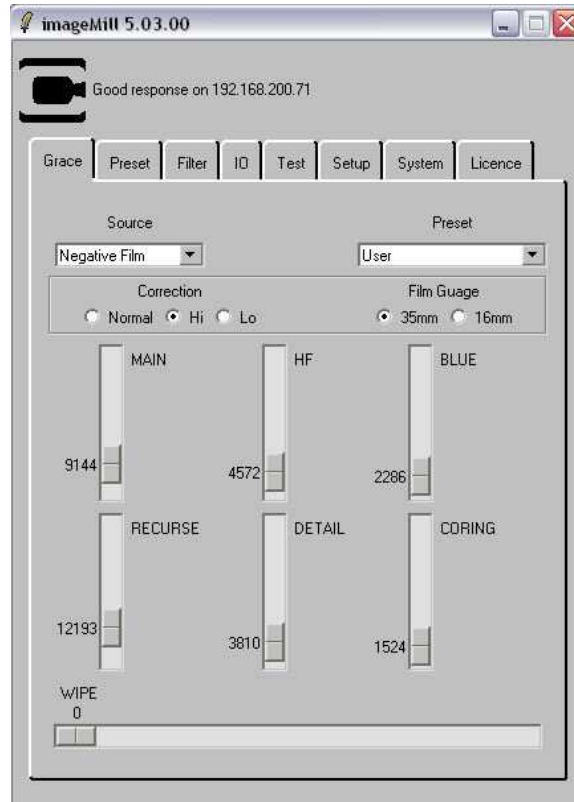

1) Main GRACE Controls

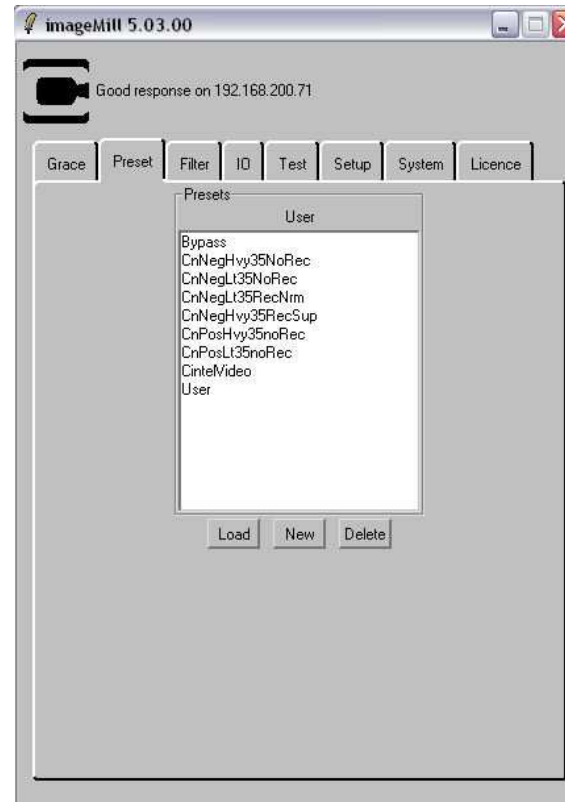

2) GRACE Preset Management

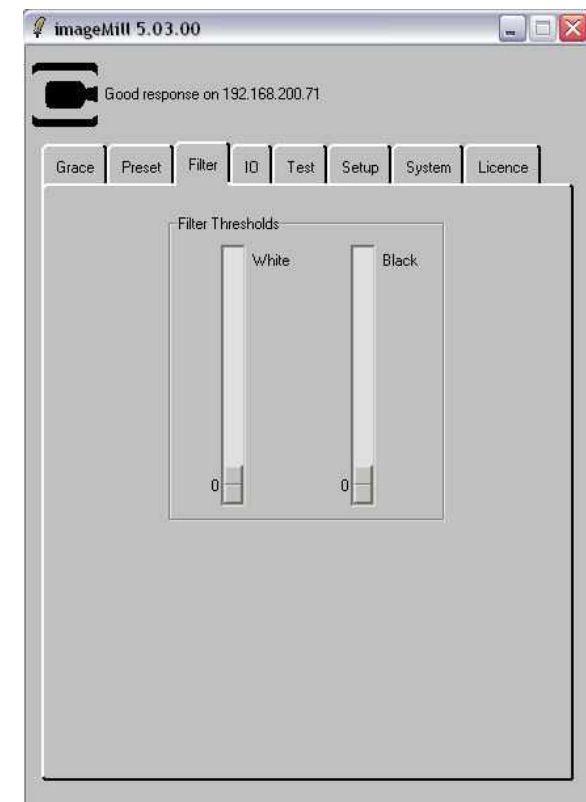

3) Dust Filter Control

Using GRACE

GRACE Wipe control

The **GRACE WIPE** control is used to show the before/after effect of Grace, and is only intended as a demonstration aid, for normal operation this control may be left in the full wipe or no wipe position, (0 or 65535) with Grace active over the whole picture in the 0 position.

Ensure this control is not partially set when Grace is in use. To confirm no Grace active, select Bypass from the **Presets** menu.

The **WIPE** function can be selected directly from the **GRACE** menu, or from the **USER** menu.

GRACE Source control



SOURCE is used to determine the origination of the images to be processed. It is essential that this selection is made to correctly reflect the ORIGINATION of the incoming images prior to adjusting any other user controls. The Origination refers to the initial imaging material. For example a video source may have originated from film rather than a video camera, in which case the source should be set to the appropriate original film material. If the origination is unknown try the various source settings for the best results. The only exception to this is when the incoming signal is presented in LOG format (this could be SD or HD but most commonly HSDL Data) when **LOG** should be selected as the source.

When using Grace keep in mind that as each film type grain structure is different and dependent upon exposure, the adjustments are unique to each image. However it will often be found that a certain set of values are suitable in general for a wide range of film transfers.

*Selection of each of the following controls brings up the corresponding function with an indication of its current value, pressing the **UP** or **Down** control button will vary and apply the new value, instantly, to the image.*

GRACE Main, HF, Blue gain control

The **MAIN** gain control should be the first level of adjustment if it is desired to change the amount of grain reduction. Increasing the level will further reduce the grain visibility but will begin to reduce the sharpness of some images. This control may be used to change the look of the picture over a range between a grainy "film look" to a flat "video look", however take care not to overdo the correction.

The **HF** gain control operates similarly to the **MAIN** gain but works on finer grain. This control in combination with the **MAIN** gain may give a better result for SDTV, or for video noise reduction.

If in doubt select zero for the **HF** gain, as excessive use may soften the image.

The **BLUE** gain control is intended to give extra correction in the blue channel for films showing excessive blue grain. **Select zero if not needed** since over-correction may result in yellow edges on some images.

GRACE Correction Modes and Film Gauge Selection

In addition to the **Normal** mode where GRACE will work evenly across all areas of the image, there is a **Highlight** Mode where GRACE will place more emphasis on correcting lighter (i.e. nearer to 'white') areas of the picture and a **Lowlight** mode where grain correction of darker, ('black') areas of the image will be emphasised.

GRACE can also be defined for use on **16mm** or **35mm** gauge source material. It is important to note that due to the random nature of Film Grain and the presence of 16mm to 35mm "blow ups" as well as 35mm to 16mm "reductions", both settings can be tried for the best result.

GRACE Detail and Coring control.

The **DETAIL** control is an additional feature provided with Grace-on-imageMill, it operates in a similar fashion to an aperture corrector to make the images sharper. Generally leave this control at its default zero setting. If it is required to make the picture a little sharper then this control may be used to correct for any slight loss of edge sharpness introduced by GRACE gain controls.

The **CORING** control is used in conjunction with the detail control. The detail control will cause the film grain and noise to become slightly more visible, and the coring control may be adjusted to minimise this effect. Generally keep the coring set to as low a value as possible to avoid coring artefacts on the image.

GRACE Presets

PRESETS comprise a set of predefined values for particular material conditions. The factory default **PRESETS** may provide an instant set up requiring very little user adjustment. The user may store up to 32 **USER** preset parameters, by use of the save function that is provided by the GUI and OEM control systems. Please note that any adjustments made locally via the imageMill control panel will not be saved.

To confirm no Grace active, select **Bypass** from the Preset menu.

GRACE Dust Filter

GRACE incorporates a simple dust reduction filter. The **White** and **Black** threshold controls can be adjusted to reduce the effect of dust. Excessive use may soften the image. The filter is applied across the whole image irrespective of the WIPE position.

Using GRACE_SR

GRACE_SR is an option for GRACE uses which adds very powerful Recursive filtering incorporating Auto Motion Management for reduction of motion artefacts. GRACE_SR is controlled by a single slider.

RECURSE Control

Increasing this control will reduce the level of Film Grain and Video Noise across the entire frame. As this control is recursive, it will not work on a still image; it requires moving images to process.

Note: GRACE_SR seems to work more efficiently with the **Correction** selection in **Highlight** mode, but experimentation is always encouraged!

Additional notes about setting up GRACE.

Prior to any adjustment ensure that the **SOURCE** selection and **GAUGE** is correctly set.

MAIN grain reduction should be the first adjustment 'experimented' with. Typical levels cannot be generalized as they depend on the film stocks and grain levels. A good starting point is around 5000; this gives a reasonable amount of reduction in most cases and is not so high as to degrade the image sharpness. If very grainy material is being processed then additional range is available, at such levels some **Detail** correction may be required. If more defined correction is required, try the **Highlight** and **Lowligh** modes.

HF control – It is somewhat difficult to describe the result of this control, it is best described as “smoothing the grain structure”. It also helps minimise any noise in the image. The levels of the **MAIN** and **HF** controls give good results when they are about equally driven.

The **RECURSE** control (if the **GRACE_SR** option is fitted) should be used in conjunction with MAIN and HF to achieve the optimum setting for noise and grain

The **Detail** aperture correction of GRACE is similar to other Aperture correction systems but perhaps simpler, it has just 2 controls. To set the **Coring**, overdrive the aperture level. Coring is introduced very slowly, just until the high frequency (Grain) is no longer enhanced. Care should be taken not to introduce too much coring or the pictures will end up looking very “edgy”. A good starting value would be between 1000 and 5000. With the coring level set, the aperture can now be backed off to the desired level. It is recommended not to use any aperture, even in HD, unless the amount of grain reduction warrants adding back some sharpness. Note that the removal of grain from an image can be perceived as making the image soft.

The **BLUE** grain control should only be used with caution, in some instances it can result in a slight yellowing around image edges. Typical usage would be for under-exposed, dark scene areas where the individual BLUE grains become prominent. Often when this control is required it will need to be set to a reasonably high level - around 20,000.

STEADY Operating Procedure

STEADY is the real-time image stabiliser option for imageMill. STEADY can be controlled by the supplied GUI application running on any PC connected to the imageMill box by Ethernet. Refer to the installation rear panel drawings for connection details. See STEADY GUI description on page 19 of this Handbook.

Once imageMill has been configured for suitable I/O signals, a number of general controls are available to the User.

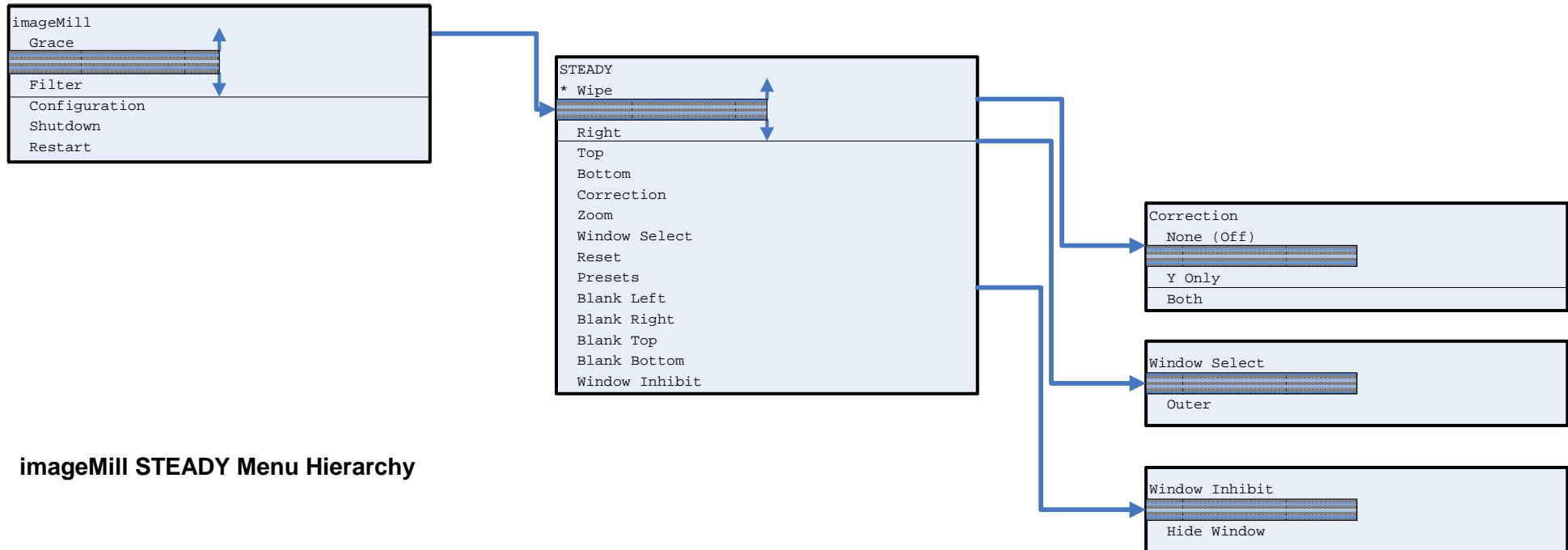

imageMill STEADY Menu Hierarchy

STEADY **Presets** are only available on the Local Control Panel. There are 5 presets which can be individually Saved or Loaded.

Window Inhibit selection available on imageMill Local Panel only. When set to 'Hide Window' this prevents the Sample Area (see page 20) from being visible when adjustments are made. This is recommended when STEADY is being operated in programmable mode.

STEADY GUI

STEADY is supplied with a Graphical User Interface (GUI) to provide control of all STEADY features (See installation section on Page 10 for details). The GUI is a simple and elegant Windows design.

1) Main Controls – Wipe and Sample Window Management

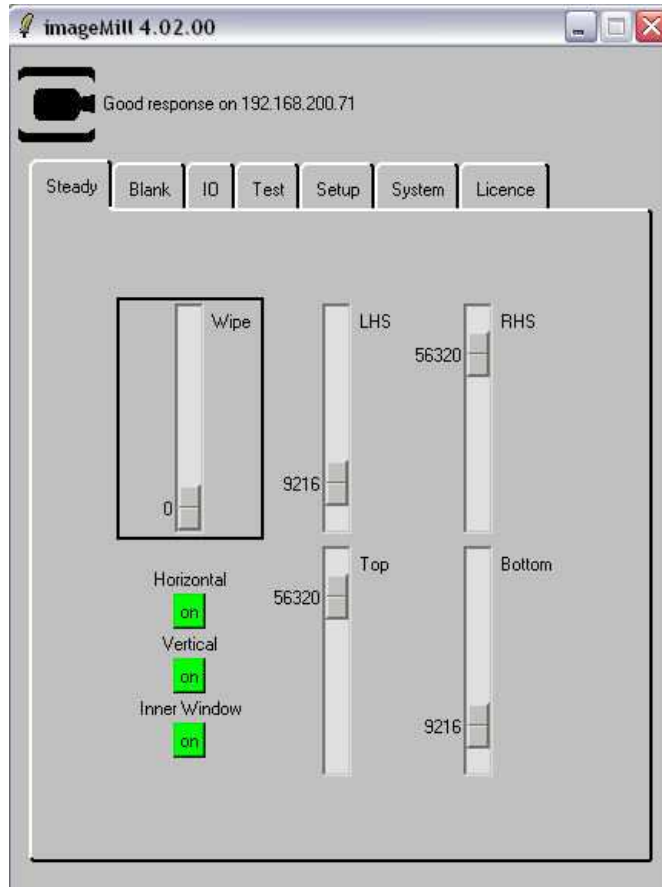

2) Blanking and Zoom Control

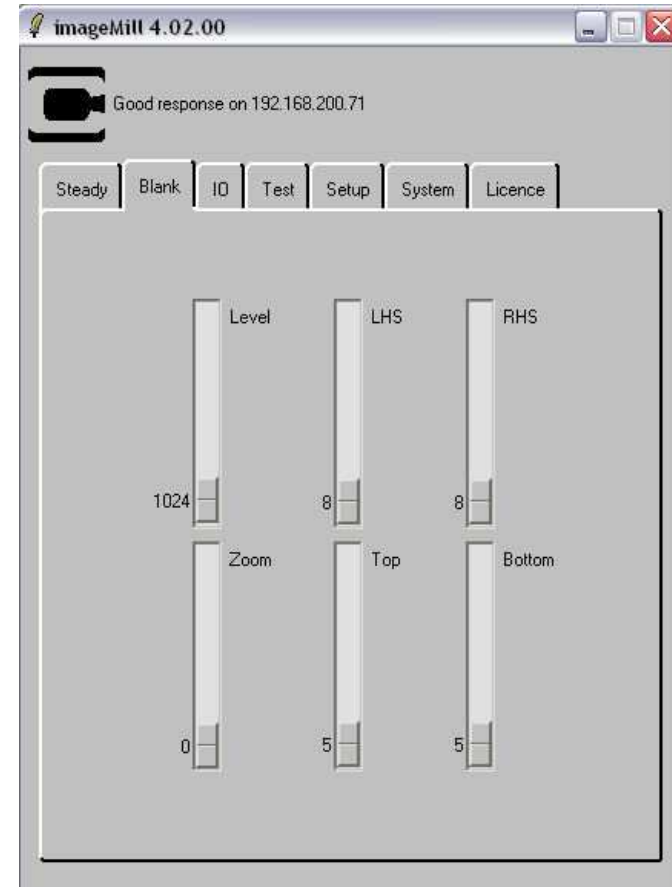

Using STEADY

STEADY Wipe control

The **STEADY WIPE** control is used to show the before / after effect of STEADY, and is only intended as a demonstration aid, for normal operation this control may be left in the full wipe or no wipe position, (0 or 65535) with STEADY active over the whole picture in the 0 position. Ensure this control is not partially set when STEADY is in use. The **WIPE** function can be selected directly from the **STEADY** menu, or from the **USER** menu.

HORIZONTAL Correction can be turned ON or OFF.

VERTICAL Correction can be turned ON or OFF.

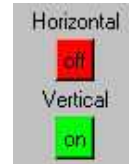

SAMPLE WINDOW control

The **SAMPLE WINDOW** controls allow setting of the **TOP**, **BOTTOM**, **LHS**, and **RHS** of a sample window. The data inside this window will be interpolated and the image stabilised using this information. This may be used to sample only a static object (a background building for example) for STEADY to stabilise, leaving other movement intact.

The **SAMPLE WINDOW IN/OUT** switch allows the data OUTSIDE the window to be interpolated.



Generally, leaving both **HORIZONTAL** and **VERTICAL** correction ON with the **SAMPLE WINDOW** IN will achieve the best results across most shots.

With **SAMPLE WINDOW** IN, STEADY will look at the information inside this window and stabilise it. This COULD have the effect of making area's outside the window look worse. An example of this would be a close-up of a person nodding their head. STEADY will try to keep the persons head stable but the effect of this could be to make the background more unstable. In this situation, switching to **SAMPLE WINDOW** OUT will stabilise the surrounding area and leave the 'nodding' action intact.

Although STEADY is intelligent enough to ignore most panning and tilting movements, switching OFF **HORIZONTAL** or **VERTICAL** may improve results on such scenes.

BLANKING control

TOP, BOTTOM, LHS and **RHS** blanking can be set. (There are also **PRESET** blanking ratios – more information to follow). This will cover any disturbances from the top, bottom, left or right of the image that may be caused by the image stabilisation process.



BLANKING Level can be set to a user-defined level of 'Black' video. This will normally be set to level 64.

ZOOM control

The **ZOOM** control allows a small amount of zoom to be applied to the corrected image. This will remove any disturbances from the top, bottom, left or right of the image that may be caused by the image stabilisation process.

Note: STEADY is an image stabiliser. If the image does not require stabilising, switch it off!

ImageMill Specification

Multi Standard Video I/O

4 x BNC Inputs	2 x Single / Dual link A-B
6 x BNC Outputs	2 x Single / Dual link A-B (Plus) 2 x Single link C, Output channel C is permanently assigned as 422 for QA / monitor purposes only.

Note: Transparent VANC & D-VITC processing RP188, 201, 215

Standard definition (SD)	422/4444 CCIR 601/656 SMPTE 259M
High definition (HD)	422/4444 SMPTE 292M/299M
High Speed Data Link (HSDL)	4444

Bit Selection 10, 12, 13 bits SMPTE 372M

Signal Processing Specification

Internal 16bit RGB Digital Signal Processing (DSP) ranged to provide standard 10bit Video I/O.

Standards Supported:

SD*	525 625	SMPTE 125 EBU 3268
HD*	720p / 60 720p / 59.94 1080i / 60 1080i / 59.94 1080i / 50 1080p / 30 1080p / 29.97 1080p / 25 1080p / 24 1080p / 23.98 1080 / 24HZ 1080 / 23.98Hz	SMPTE 296 – 1 SMPTE 296 – 2 SMPTE 274 – 4 SMPTE 274 – 5 SMPTE 274 – 6 SMPTE 274 – 7 SMPTE 274 – 8 SMPTE 274 – 9 SMPTE 274 – 10 SMPTE 274 – 11 SMPTE 274 – 12 SMPTE 274 – 13
Digital Projection*	2048x1080 / 24 2048x1080 / 23.98	
HSDL (Dual stream)*	2048x1556 / 14.985 2048x1556 / 15 4096x3112 / 3.745 "Pixelpacker" format 4096x3112 / 3.75 "Pixelpacker" format	

*optional

Communications

Network control	100bT (1 xRJ45)
Remote interface	RS422 (2 x 9way D-type)

User Interface

Local 4 line Vacuum Fluorescent Display
 Local 4 button user Interface
 Remote PC compliant toolbox GUI
 3rd Party controller systems – i.e. daVinci, Pandora, Tangent Devices

Power:

Type	Single 180W ATX compatible
Input Voltage Range	90-265V 47/63Hz Auto sensing
Consumption	180W max, 110W nominal
Mains Fuse Rating	2A (T) 250V

Mechanical:

Temperature Range	15-35°C Operational.
Cooling	2 Axial fans. LH Top / RH side to rear airflow.
Case format	19" 1RU Rack mounting (with removable front brackets & / or provision for rear support brackets).
Dimensions	445mm x 485x 45mm (wxdxh).
Weight	7.5Kg.
Approvals	CE / EN60950.

General:

Utilities	Internal test pattern generator Luma Ramp, Border, 100% Bars, 75% Bars, Hue sweep, Freq Sweep, Combined,
Environment Monitoring	Voltage and Temperature

Software Upgrade

If the software is provided on CD then you will need to move the .civ file onto the local drive, if from the ftp site, then you will have to unzip to the local drive to obtain the .civ file. Both remove and install operations require the password “cintel”.

From the **Setup** panel select **Transfer**. This will open a dialog box which will allow you to navigate to the required .civ file. Select this file and, after a number of seconds it will appear in the “**Installs on target**” area. Highlight the required software version then select **Install**. This will cause the imageMill to automatically restart. The **Software currently installed** area can be used to check a successful installation.

If there has been a major software version change, e.g. from 3.01.00 to 4.00.00 a new licence will be required; this will be indicated on the front panel.

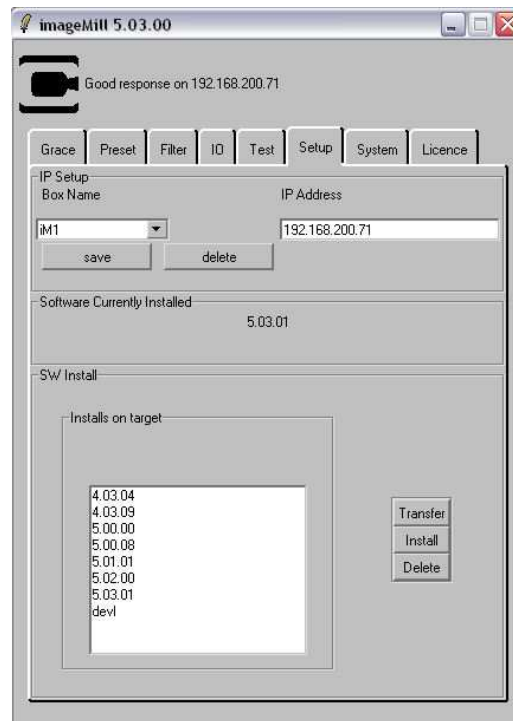

1) Set up Panel

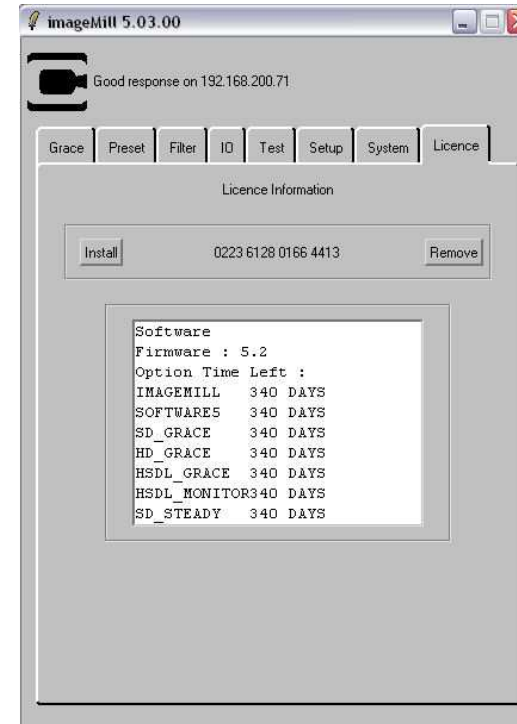

2) License management

Licence Renewal

If increasing the licence period or adding further options, a new licence will need to be installed. License requirement will be indicated by the Front Panel or by Test Pattern Colour Bars being constantly displayed.

Request Cintel for a new licence file, and provide the 16 digit number which can be obtained from the **License** panel.

Put the new licence file on the same PC as the GUI, and from the **License** panel press the **Install** button. A browser will pop up, select the .lic file and ok. The imageMill box should restart automatically.

Note. If removing options or reducing the licence period, then the existing licence must be removed, by pressing the **remove** button on the setup panel.

“CINTEL INTERNATIONAL LIMITED SOFTWARE/FIRMWARE LICENCE”

PLEASE READ THIS DOCUMENT CAREFULLY BEFORE SIGNING AND RETURNING TO CINTEL. BY SIGNING THIS DOCUMENT, YOU AGREE TO BE BOUND BY THE TERMS OF THIS SOFTWARE/FIRMWARE LICENCE.

This Software, Firmware and associated printed material is licensed to you (“the Licensee”) by Cintel International Limited of Watton Road, Ware, Hertfordshire SG12 OAE (“Cintel”) for use with the Cintel Equipment for which the Software and Firmware is designed (“the Equipment”). Copyright and all other rights in the information contained within the disk(s) and supplied by Cintel shall at all times remain in the ownership of the supplier.

1.CINTEL’S LICENCE

This Software/Firmware Licence is granted by Cintel or by Cintel acting as an agent for the owner of the software and is subject to the following:

Cintel hereby agree;

- (a) to license the Licensee to use one copy of the Software/Firmware for use with the Equipment.
- (b) providing the Licensee returns a signed copy of this document;
 - (i) to supply free updates if applicable to the Software/Firmware for a period of six months commencing from the date of receipt by the Licensee of the Software/Firmware.
 - (ii) to replace the Software/Firmware at the Licensee’s expense should it become lost or damaged.
 - (iii) to provide timed licenses where deemed appropriate.

2.PERMITTED USE

- (a) The Licensee shall promptly on receipt, where the Software/Firmware is not preloaded in the Equipment, load the Software/Firmware in its entirety including any copyright notices and statement of ownership onto the Equipment.
- (b) The Licensee shall store the master Software/Firmware disk(s) in secure storage in the envelope or within the equipment as appropriate.
- (c) The Software/Firmware may be used only on and in relation to the Equipment in the ordinary course of the Licensee’s business.

3.RESTRICTIONS ON THE LICENSEE

- (a) The Licensee save as required for its own internal use or as permitted by law shall not itself nor permit or facilitate its employees, agents or any third party to copy, publicly display, transmit or make any adaptation or modification of the Software/Firmware.
- (b) The Licensee shall not remove or permit to be removed any copyright notice on the Software/Firmware nor any statement of ownership which may be affixed thereto.
- (c) The licence is personal to the Licensee who shall not transfer it or grant any sub licences without Cintel’s written consent which shall not be unreasonably withheld where the proposed transfer is in respect of the sale of Equipment to a bona fide user and the purchaser has consented to accept these licence terms and provided the Licensee retains no copies of the Software/Firmware including any printed materials. A transfer fee may be required.
- (d) The Licensee shall not be permitted to transfer the licence to any USA or other government agency unless such transfer is in accordance with the procedures (which are available on request) contained in any third party licence the Licensor holds in respect of third party Software/Firmware contained in the Equipment.

4.ACCESS

The Licensee shall permit Cintel's representatives to have access at all reasonable times to the Software/Firmware and any records relating to its use.

5.WARRANTIES

Cintel warrants that when loaded with the Software/Firmware the Equipment will substantially operate in accordance with Cintel's written specification.

6.LIMITATION OF LIABILITY

- (a) AS THERE IS NO SPECIFIED VALUE FOR THIS LICENCE, AND THIS LICENCE IS UNRELATED TO A PARTICULAR USE TO WHICH THE LICENSEE INTENDS TO APPLY THE SOFTWARE/FIRMWARE, CINTEL MAKES NO WARRANTIES IN RELATION TO THE PERFORMANCE OF THE SOFTWARE/FIRMWARE OR ITS FITNESS FOR ANY PARTICULAR PURPOSE.
- (b) Cintel or its employees shall not be liable for any consequential incidental or indirect damages arising out of the use or inability to use the Software/Firmware or accompanying written materials.
- (c) Cintel's liability for actual damages for any cause whatsoever will be limited to the value of the media on which the Software/Firmware is supplied.
- (d) Warranty claims made pursuant to Clause 5 shall be invalid unless received in writing by Cintel prior to six months from the date of the invoice for the Equipment.

7.APPLICABLE LAW

This Licence shall be interpreted in accordance with the laws of England and the Licensee hereby submits to the exclusive jurisdiction of the English Courts.

Product Serial Number _____

Software Version _____

Licensee Name _____

Licensee Position Title _____

Licensee Signature* _____

Date _____

For Cintel International _____

*Only the initial 28-day license will be issued until this document is received by Cintel International with an official Licensee signature